

20 to 65 W High Density Programmable Constant Current Class 2 LED Driver with 0-10 V Dimming, and with Optional Auxiliary Output

Input Voltage (Vac)	Max. Output Power (W)	Output Voltage (Vdc)	Output Current (mA)	Efficiency	Max. Case Temperature	THD	Power Factor	Dimming Method	Dimming Range	Startup Time
120 - 277	65	10 - 55	100 - 1800	up to 92% typical	Life : 85°C UL : 90°C	< 20% @ max load	> 0.9	0 - 10V with Dim-to-Off	1 - 100%	300 ms typical

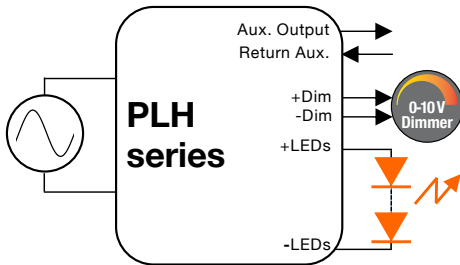

Side Leads Case
 L 197.4 * W 19.65 * H 19.25 mm
 (L 7.77 * W 0.77 * H 0.76 in.)



Application Diagram

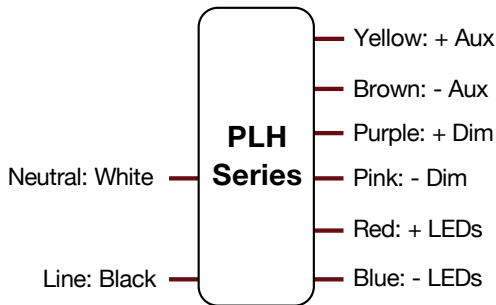

Wiring Diagram

FEATURES

- Up to 92% efficient
- Lifetime: 50,000 hours @ Tc ≤ 85°C
- Extended Lifetime: 100,000 hours at Tc ≤ 75°C
- Current tolerance up to ±2% typical
- Meets IEEE 1789-2015 “no impact” recommended practices for flicker
- Synchronized start-up: 100 ms
- Programmable dim-to-off for compliance with ANSI C137.1
- Optional programmable auxiliary output
- 0.5 W max standby power
- UL8750 Class P, Class 2 power supply
- 90°C maximum case hot spot temperature
- Surge protection:
 - IEC61000-4-5: 3 kV line to line/3 kV line to earth
 - 2.5 kV ring wave: ANSI/IEEE c62.41.1-2002 & c62.41.2-2002 category A
- Complies with ENERGY STAR®, DLC, and CA Title 24

PROGRAMMING

- Audio jack programming
- Current: see page 2 for current range
- 0-10V dimming profiles: Linear, Non-linear, Logarithmic
- Data log read: SKU, S/N, lot code, hours of operation, FW rev., power cycles

APPLICATIONS

- Commercial & Office lighting
- Architectural lighting
- Indoor Lighting

CERTIFICATIONS / STANDARDS



20 to 65 W High Density Programmable Constant Current Class 2 LED Driver with 0-10 V Dimming, and with Optional Auxiliary Output

1 - ORDERING INFORMATION

Part Number	Nominal Input Voltage (Vac)	Max Output Power (W)	I _{out} (mA) ⁽¹⁾	Default Programmed Current (mA)	V _{out} Min. (Vdc)	V _{out} Nom. (Vdc)	V _{out} Max. (Vdc) ⁽²⁾	Open Loop (No Load) Voltage (Vdc)	Notes
Up to 20W									
PLH-A20W-07-55-SZ	120 - 277	20	100 to 700	350	10	49.5	55	60	
PLH-A20W-07-55-SXZ	120 - 277	20	100 to 700	350	10	49.5	55	60	with auxiliary output
Up to 30W									
PLH-A30W-10-55-SZ	120 - 277	30	275 to 1050	700	10	49.5	55	60	
PLH-A30W-10-55-SXZ	120 - 277	30	275 to 1050	700	10	49.5	55	60	with auxiliary output
Up to 50W									
PLH-A50W-14-55-SZ	120 - 277	50	500 to 1400	1050	10	49.5	55	60	
PLH-A50W-14-55-SXZ	120 - 277	50	500 to 1400	1050	10	49.5	55	60	with auxiliary output
Up to 65W									
PLH-A65W-18-55-SZ	120 - 277	65	600 to 1800	1200	10	49.5	55	60	
PLH-A65W-18-55-SXZ	120 - 277	65	600 to 1800	1200	10	49.5	55	60	with auxiliary output

NOTES:

- (1) The ERP LED Driver Configuration Tool (ERP GUI) allows programming of the output current to values below the minimum limits specified in the table above. However, when the programmed output current is set below these minimum thresholds, the LED driver's Total Harmonic Distortion (THD) and Power Factor (PF) may not meet the values defined in the INPUT SPECIFICATION section of this datasheet. For proper operation, please also refer to the OPERATING ENVELOPE for each part number, which defines the permissible ranges of output current and output voltage where THD and PF compliance is maintained.
- (2) The forward voltage (V_f) of the LED load should not exceed V_{out} Max. of the driver under worst case field operating conditions which are the V_f max. of the LED load under lowest temperature and highest forward current conditions. As a general design guideline, the nominal LED load V_f measured at the operating current and at room temperature should be ≤ V_{out} Nom. of the driver.

2 - ACCESSORIES

NOTES:

- Please order the programming cable using part number **PROG-JACK-USB**.
- The optional programming cradle can be ordered using part number **PROG-PLH-CRADLE**

Programming Cradle
 Part number: PROG-PLH-CRADLE

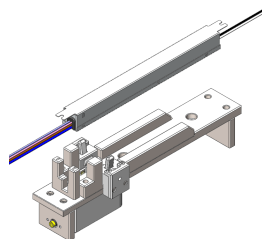

Programming Cable
 Part number: PROG-JACK-USB



Figure 1

20 to 65 W High Density Programmable Constant Current Class 2 LED Driver with 0-10 V Dimming, and with Optional Auxiliary Output

3 - OPERATING ENVELOPES

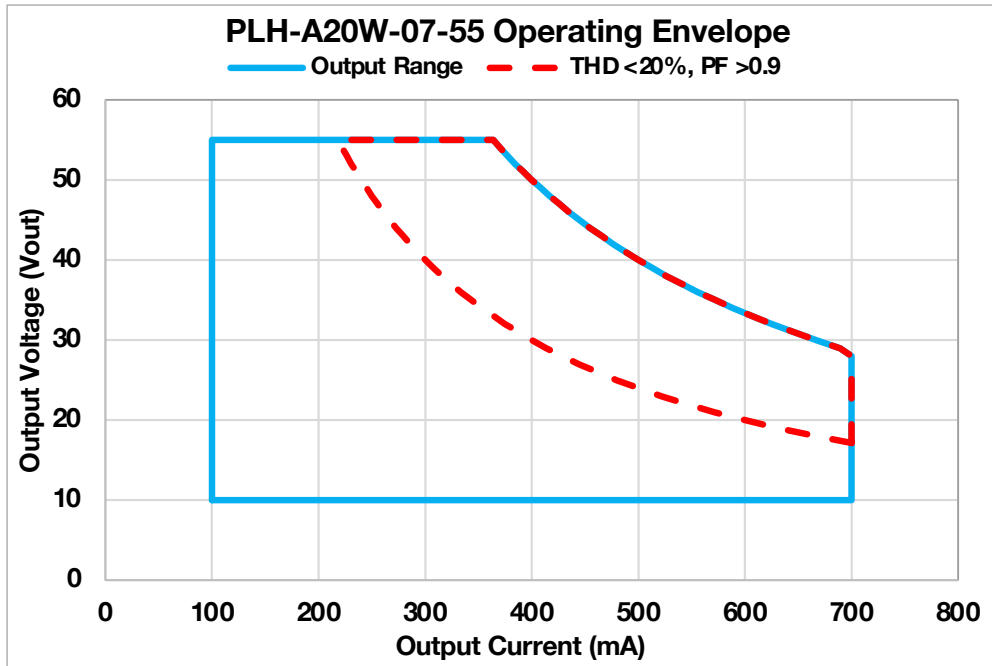

Figure 2

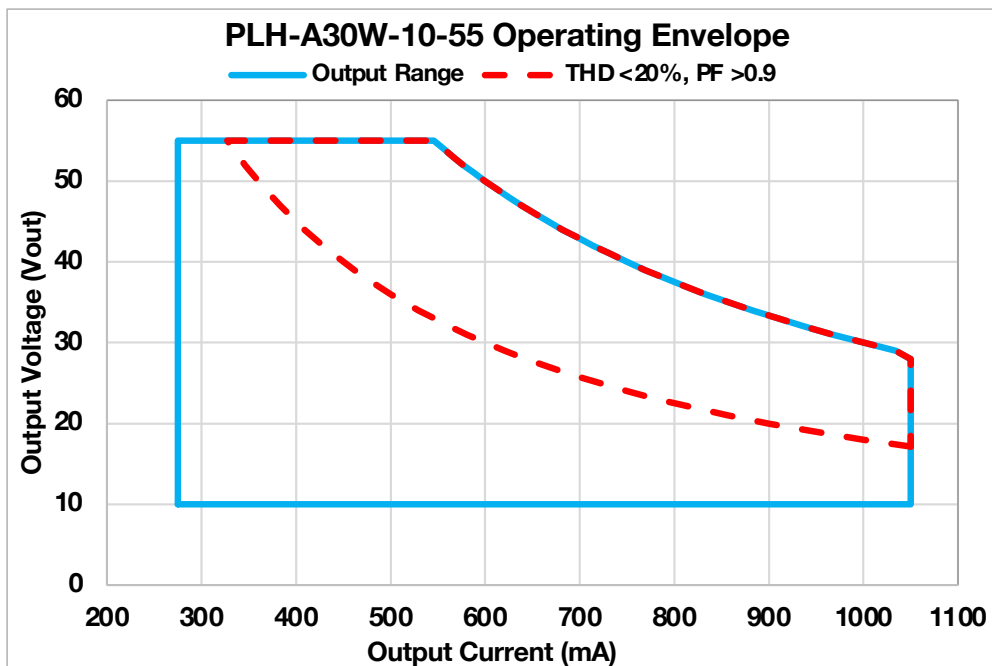

Figure 3

20 to 65 W High Density Programmable Constant Current Class 2 LED Driver with 0-10 V Dimming, and with Optional Auxiliary Output

3 - OPERATING ENVELOPES (CONTINUED)

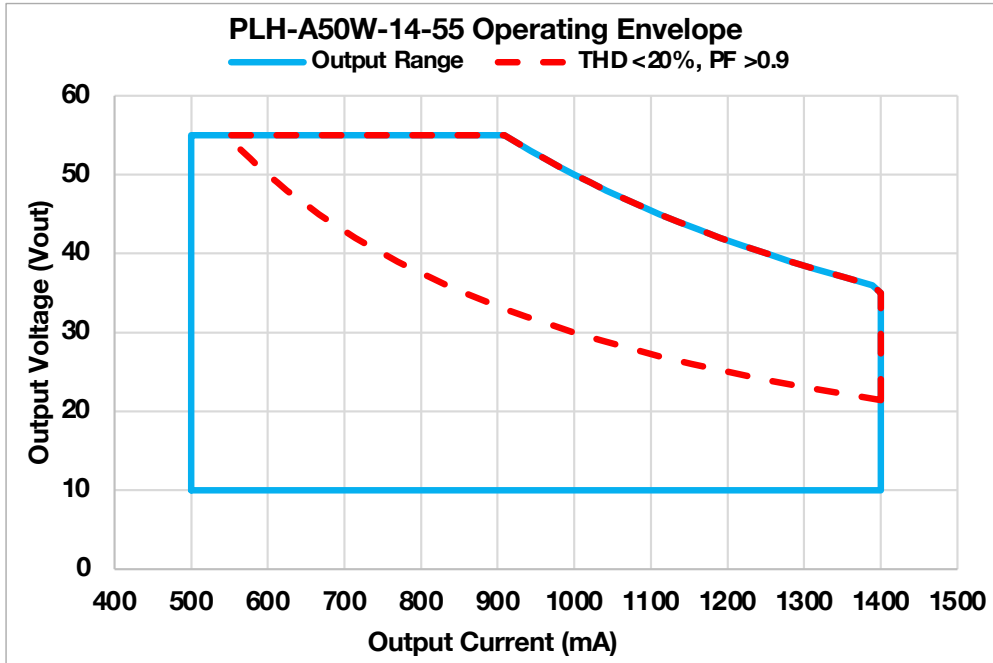

Figure 4

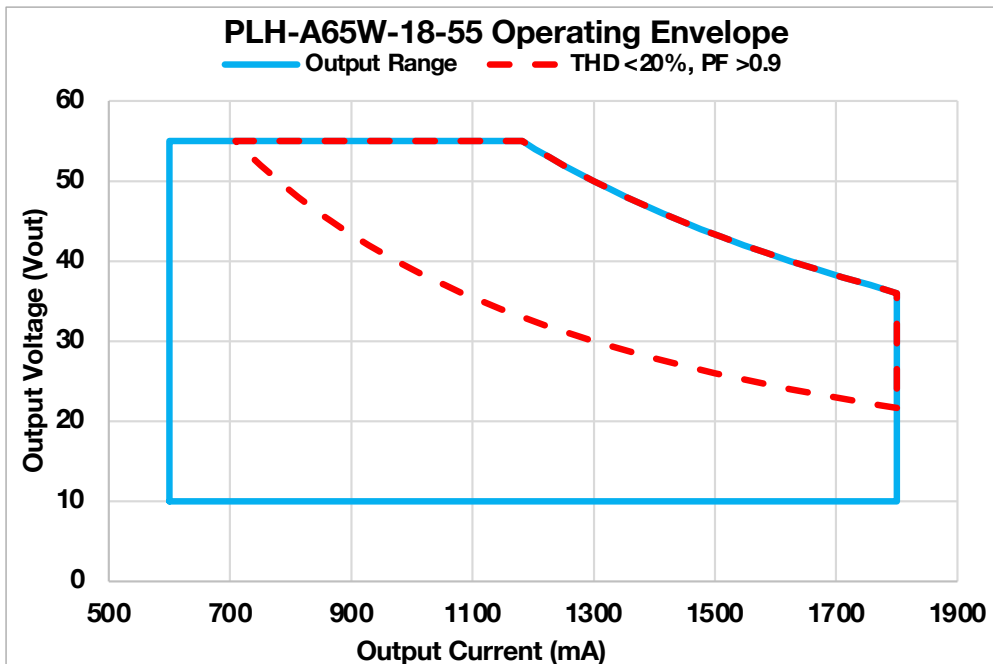

Figure 5



POWER + LIGHT™

PLH Series

PLH-A20 20 W
PLH-A30 30 W
PLH-A50 50 W
PLH-A65 65 W

20 to 65 W High Density Programmable Constant Current Class 2 LED Driver with 0-10 V Dimming, and with Optional Auxiliary Output

■ 4 - INPUT SPECIFICATION (@25°C ambient temperature)

	Units	Minimum	Typical	Maximum	Notes
Input Voltage Range (Vin)	Vac	108	120 - 277	305	<ul style="list-style-type: none"> The rated output current for each model is achieved at $V_{in} \geq 108$ Vac, and at $V_{in} \geq 249$ Vac. At nominal load
Input Frequency Range	Hz	47	50/60	63	-
Input Current (Iin)	A	-	-	0.7 A @ 120 Vac 0.35 A @ 277 Vac	-
Power Factor (PF)	-	0.9	> 0.9	-	<ul style="list-style-type: none"> At nominal input voltage (120 & 277 Vac) and no dimmer From 100% to 60% of output power (from 100% to 70% of output power for PLH-A20 models)
Inrush Current	A	Meets NEMA-410 requirements			At any point on the sine wave and 25°C
Leakage Current	mA	-	-	0.3 mA @ 120 Vac 0.7 mA @ 277 Vac	Measured per IEC60950-1
Input Harmonics	Complies with IEC61000-3-2 for Class C equipment				
Total Harmonics Distortion (THD)	-	-	-	20%	<ul style="list-style-type: none"> At nominal input voltage (120 & 277 Vac) From 100% to 60% of output power (from 100% to 70% of output power for PLH-A20 models) Complies with DLC (Design Light Consortium) technical requirements
Efficiency	%	-	up to 92%	-	Measured with nominal input voltage, a full sinusoidal wave form and without dimmer attached.
Standby Power	mW	-	-	500 1000	<ul style="list-style-type: none"> At 120 Vac At 277 Vac
Isolation	The AC input to the main DC output is isolated.				

20 to 65 W High Density Programmable Constant Current Class 2 LED Driver with 0-10 V Dimming, and with Optional Auxiliary Output

■ 5 - MAIN OUTPUT SPECIFICATION (@25°C ambient temperature)

	Units	Minimum	Typical	Maximum	Notes
Output Voltage (Vout)	Vdc	-	-	-	•See ordering information for details
Output Current (Iout)	mA	-	-	-	•See ordering information for details •Output voltage and current combination cannot exceed max power output. See page 3 for operating window •The rated output current for each model is achieved at $V_{in} \geq 108$ Vac & $V_{in} \geq 249$ Vac.
Output Current Regulation	%	-5	±2	5	•At nominal AC line voltage (120 & 277 Vac) •Includes load and current set point variations
Output Current Overshoot	%	-	-	20	The driver does not operate outside of the regulation requirements for more than 500 ms during power on with nominal LED load and without dimmer.
Ripple Current	≤ 10% of max output current for each model				•Measured at nominal LED voltage and nominal input voltage without dimming •Calculated in accordance with the IES Lighting Handbook, 9th edition •Compliant with IEEE1789-2015. Meets "No Impact" levels.
Dimming Range	%	1	-	100	•The dimming range is dependent on each specific dimmer. It may not be able to achieve 1% dimming with some dimmers. •When testing, if light is measured, dimming range is based on light output. If no light is measured, dimming range is based on percentage of output current. •Dimming performance is optimal when the driver is operated at its nominal output voltage matching the LED nominal Vf (forward voltage). Dimming performance may vary when the driver is operated near its minimum output voltage.
Start-up Time	ms	-	300	500	•Without any dimmer attached, and at nominal input voltages and nominal load •Synchronized start-up of 100 ms when multiple drivers on same circuit •Measured from application of AC line voltage to 100% light output •Complies with ENERGY STAR® luminaire specification and CA Title 24
Isolation	The main DC output is certified and tested per UL8750 Class 2 or LED Class 2.				

■ 6 - AUXILIARY OUTPUT SPECIFICATION "-SXZ" MODELS ONLY (@25°C ambient temperature)

	Units	Minimum	Typical	Maximum	Notes
Auxiliary Output Voltage	Vdc	9.5	12	24	•Default value is 12 V •+/-20% voltage regulation •Configurable through programming in 0.5 V increments
Auxiliary Output Power	W			1.2	

20 to 65 W High Density Programmable Constant Current Class 2 LED Driver with 0-10 V Dimming, and with Optional Auxiliary Output

7 - DEFAULT 0-10 V DIMMING PROFILE (@25°C ambient temperature)

Using the ERP LED Driver Configuration Tool (ERP GUI), users can select from several 0–10V dimming profiles, including a logarithmic profile, an ANSI C137.1-compliant profile, and non-linear profiles with either 1% or 10% minimum dimming, each available with or without dim-to-off.

Dim-to-off can be enabled or disabled independently, and a fully user-defined dimming profile can also be created, allowing precise programming of every point along the dimming curve.

By default, the PLH series is pre-loaded with the non-linear profile featuring 1% minimum dimming with dim-to-off, as shown in Figure 6.

	Units	Minimum	Typical	Maximum	Notes
Default Dimming Profile (see figure 6)		100% of output current between 10 V and 8 V, Linear between 8 V and 1 V, 1% of output current below 1 V.			
Dimming Range	%	1		100	When testing, if light is measured, dimming range is based on light output. If no light is measured, dimming range is based on percentage of output current.
High Level Voltage - A	V		8.0		
Low Level Voltage - B	V		1.0		
Dim to Off - C	V		0.7		
Dim to On - D	V		0.9		
Current Supplied by the +Dim Signal Pin	mA			0.5	
Dimming Voltage Sensing Tolerance	mV			100	The tolerance of the difference between the 0-10 V signal supplied by the dimmer and sensed by the driver.
Output Current Tolerance While Being Dimmed	%		±8		In the linear region of the dimming curve (between points A and B in Figure 6).
Output Current Tolerance at Minimum Dimming	%	0.5		2	The tolerance of the output current at minimum dimming varies from 0.5% of 2% of the programmed output current of each driver.
Isolation	The 0-10 V circuit is isolated from the AC input and meets UL8750 supplement SF requirements.				

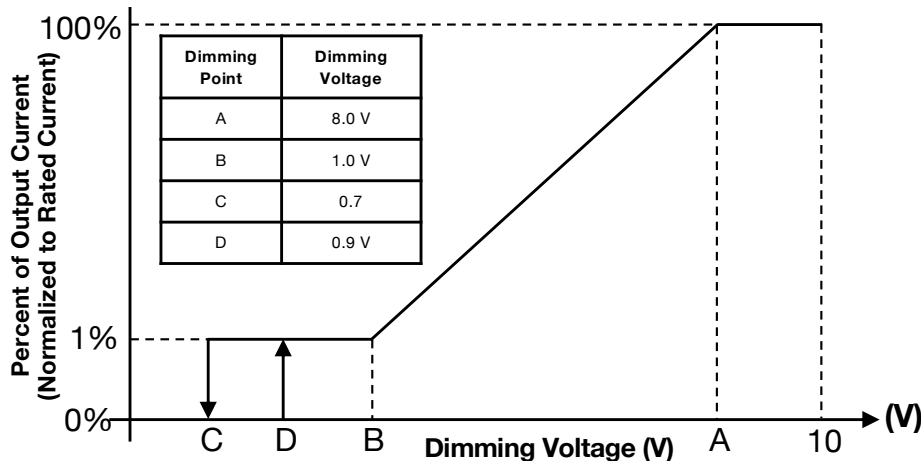

Figure 6



POWER + LIGHT™

PLH Series

PLH-A20 20 W
PLH-A30 30 W
PLH-A50 50 W
PLH-A65 65 W

20 to 65 W High Density Programmable Constant Current Class 2 LED Driver with 0-10 V Dimming, and with Optional Auxiliary Output

8 - ENVIRONMENTAL CONDITIONS

	Units	Minimum	Typical	Maximum	Notes
Operating Ambient Temperature (Ta)	°C	-20	-	50	50°C is the non-derated temperature (Refer to section 12 'Output power de-rating at elevated temperatures'.)
Maximum Case Temperature (Tc)	°C	-	-	+90	Case temperature measured at the hot spot •tc (see label on page 20)
Storage Temperature	°C	-40	-	+85	-
Humidity	%	5	-	95	Non-condensing
Cooling	Convection cooled				-
Acoustic Noise	dBa	-	-	24	Measured at a distance of 1 foot, with dimmer
Mechanical Shock Protection	per EN60068-2-27				-
Vibration Protection	per EN60068-2-6 & EN60068-2-64				-
MTBF	> 200,000 hours when operated at nominal input and output conditions, and at Tc ≤ 90°C				
Lifetime	50,000 hours at Tc ≤ 85°C maximum case hot spot temperature (see hot spot •tc on label on page 20) 100,000 hours possible at Tc ≤ 75°C. See table on Page 13				
Warranty	5 years. Users must utilize proper thermal management techniques to ensure proper thermal conductivity between the driver and heat sink. The use of double-sided tape to mount the driver voids the warranty.				

9 - EMC COMPLIANCE, SAFETY, AND ENVIRONMENTAL APPROVALS

EMC Compliance					
Conducted and Radiated EMI	•Compliant with FCC CFR Title 47 Part 15 Class A at 120 & 277 Vac				
Voltage Fluctuations & Flicker	IEC61000-3-3		-		
Immunity Compliance	ESD (Electrostatic Discharge)	IEC61000-4-2	6 kV contact discharge, 8 kV air discharge, level 3		
	RF Electromagnetic Field Susceptibility	IEC61000-4-3	3 V/m, 80 - 1000 MHz, 80% modulated at a distance of 3 meters		
	Electrical Fast Transient	IEC61000-4-4	± 2 kV on AC power port for 1 minute, ±1 kV on signal/control lines		
	Surge	IEC61000-4-5	± 3 kV line to line (differential mode) /± 3 kV line to common mode ground		
			ANSI/IEEE c62.41.1-2002 & c62.41.2-2002 category A, 2.5 kV ring wave		
	Conducted RF Disturbances	IEC61000-4-6	3V, 0.15-80 MHz, 80% modulated		
		IEC61000-4-11	>95% dip, 0.5 period; 30% dip, 25 periods; 95% reduction, 250 periods		
Safety & Environmental Approvals					
UL	UL8750 listed Class 2, supplement SF				
cUL	CAN/CSA C22.2 No. 250.13-14 LED equipment for lighting applications				
Safety					
	Units	Minimum	Typical	Maximum	Notes
Hi Pot (High Potential) or Dielectric voltage-withstand	Vdc	2200			•Tested at the RMS voltage equivalent of 1555 Vac



POWER + LIGHT™

PLH Series

PLH-A20	20 W
PLH-A30	30 W
PLH-A50	50 W
PLH-A65	65 W

20 to 65 W High Density Programmable Constant Current Class 2 LED Driver with 0-10 V Dimming, and with Optional Auxiliary Output

10 - DIMMING FEATURES

Synchronized Start-up

The LED Driver incorporates a synchronized start-up feature. When wired into the same dimmer, multiple PLH series drivers will dim to the same level and turn on within 100 ms of each other.

Fully Programmable Dimming Curve

Users can configure multiple 0–10V dimming profiles via the ERP LED Driver Configuration Tool (ERP GUI), including logarithmic, ANSI C137.1-compliant, and non-linear options with 1% or 10% minimum dimming, with or without dim-to-off.

Dim-to-off can be enabled or disabled independently, and a fully user-defined dimming profile can also be created, allowing precise programming of every point along the dimming curve.

11 - PROTECTION FEATURES

Input Over Current Protection

The LED Driver incorporates a primary AC line fuse for input over current protection to prevent damage to the LED driver and meet product safety requirements as outlined in Section 9.

Short Circuit and Over Current Protection

The LED Drivers protected against short-circuit such that a short from any output to return shall not result in a fire hazard or shock hazard. The driver operates in a hiccup mode if a short circuit or over current fault occurs. Removal of the fault will return the driver to within normal operation. The driver shall recover, with no damage.

Internal Over temperature Protection

The LED Driver is equipped with internal temperature sensor on the primary power train. Failure to stay within the convection power rating will result in the power supply reducing the available current (fold back) below the programmed amount. The main output current will be restored to the programmed value when the temperature of the built-in temperature sensor cools adequately.

Output Open Load Protection

When the LED load is removed, the output voltage of the PLH series is typically limited to 60 V, to meet Class 2 standard.

0-10V Dimming Circuit Protection

The 0–10V dimming circuit includes built-in protection against accidental mis-wiring, preventing damage even if AC line voltage is mistakenly connected to the dimming leads at any nominal input voltage.

12 - OUTPUT POWER DE-RATING AT ELEVATED TEMPERATURES

The LED Driver can be operated with cooling air temperatures above 50°C by linearly de-rating the total maximum output power (or current) by 2.5%/°C until internal over temperature protection activates.

20 to 65 W High Density Programmable Constant Current Class 2 LED Driver with 0-10 V Dimming, and with Optional Auxiliary Output

13 - 0-10 V DIMMING

The LED Driver operate only with 0-10 V dimmers that sink current. They are not designed to operate with 0-10 V control systems that source current, as used in theatrical/entertainment systems. Developed in the 1980's, the 0-10 V sinking current control method is adopted by the International Electrotechnical Commission (IEC) as part of its IEC Standard 60929 Annex E.

The method to dim the output current of the driver is done via the +Dim/-Dim Signal pins. The +Dim/-Dim Signal pins respond to a 0 to 10 V signal, delivering 1% to 100% of the output current based on rated current for each model. A pull-up resistor is included internal to the driver. If the +Dim input is > 10 V or open circuited, the output current is programmed to 100% of the rated current.

The maximum source current (flowing from the driver to the 0-10 V dimmer) supplied by the +Dim Signal pin is ≤ 0.5 mA. The tolerance of the output current while being dimmed shall be $\pm 8\%$ typical until down to 1 V.

Using the ERP LED Driver Configuration Tool (ERP GUI), users can select from several 0-10V dimming profiles, including a logarithmic profile, an ANSI C137.1-compliant profile, and non-linear profiles with either 1% or 10% minimum dimming, each available with or without dim-to-off.

Dim-to-off can be enabled or disabled independently, and a fully user-defined dimming profile can also be created, allowing precise programming of every point (A, B, C, D) along the dimming curve.

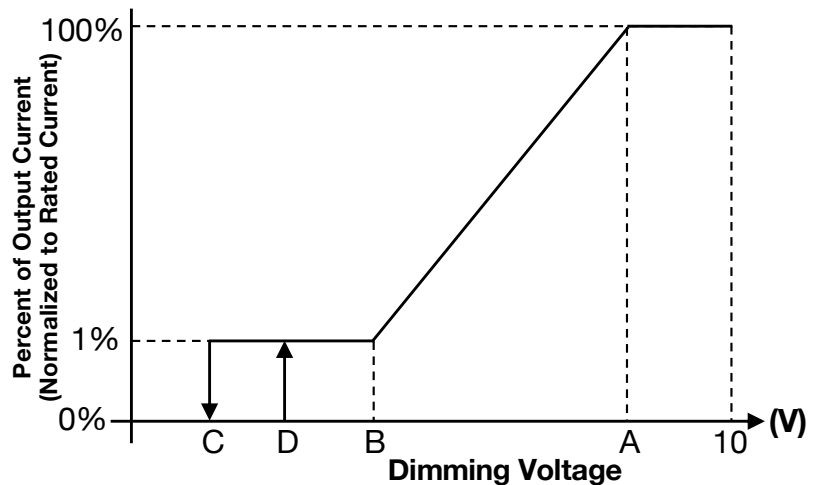

Figure 7

	Units	Minimum	Typical	Maximum	Tolerance	Notes
Dimming Range	%	1		100		When testing, if light is measured, dimming range is based on light output. If no light is measured, dimming range is based on percentage of output current.
High Level Voltage - A (Recommended Range)	V	7.0		9.0	± 100 mV	Point A can actually be programmed to any value but it should never go below Point B.
Low Level Voltage - B (Recommended Range)	V	1.0		2.0	± 100 mV	Point B can actually be programmed to any value but it should never go beyond Point A.
Dim to Off Range - C (Recommended Range)	V	0.5		1.0	± 100 mV	
Dim to On Range - D (Recommended Range)	V	0.7		1.0	± 100 mV	
Current Supplied by the +Dim Signal Pin	mA			0.5		
Dimming Voltage Sensing Tolerance	mV				100	The tolerance of the difference between the 0-10 V signal supplied by the dimmer and sensed by the driver.
Output Current Tolerance While Being Dimmed	%				± 8	In the linear region of the dimming curve (between points A and B in Figure 7).
Output Current Tolerance at Minimum Dimming	%	0.5		2		The tolerance of the output current at minimum dimming varies from 0.5% to 2% of the programmed output current of each driver.

20 to 65 W High Density Programmable Constant Current Class 2 LED Driver with 0-10 V Dimming, and with Optional Auxiliary Output

14 - COMPATIBLE 0-10 V DIMMERS

Lutron	Leviton
Nova series: NFTV	IllumaTech series: IP710-DL
Diva Series: DVTV	

NOTE: Dimming compatibility charts are available for each model on the PLH series page at: erp-power.com.

15 - CONNECTION AND COMPATIBILITY WITH EXTERNAL SENSORS

The PLH series is compatible with the Lutron Athena wireless node when programmed as an ANSI C137.1 0-10 V driver.



Athena RF Wireless Node

Athena Wireless Node Wiring Guide

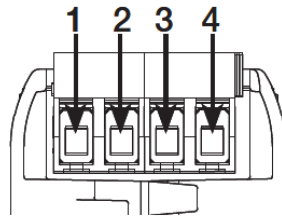

Athena Connector Description	ERP LED Driver Wiring
1: AUX+	+Aux (Yellow)
2: AUX-	-Aux (Brown)
3: SIG+	+Dim (purple)
4: SIG-/DGND	-Dim (pink)

Connecting an Athena Wireless Sensor Node to an ERP LED Driver with Auxiliary Output (e.g. PLH, PLH, PLS series):

- Connect the AUX+ of Athena to the +Aux (yellow) wire of the ERP LED Driver
- Connect the AUX- of Athena to the -Aux (brown) wire of the ERP LED Driver
- Connect the SIG+ of Athena to the +Dim (purple) of the ERP LED Driver
- Connect the SIG- of Athena to the -Dim (pink) of the ERP LED Driver

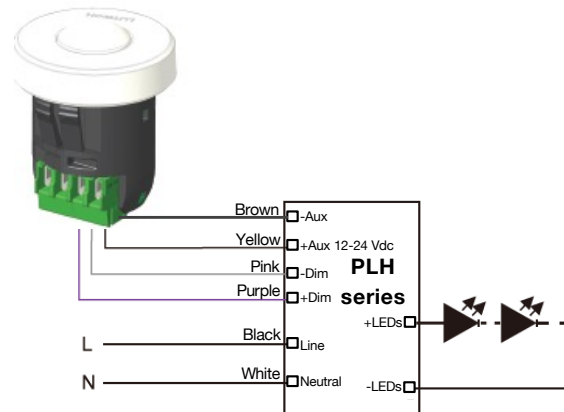

Figure 8

20 to 65 W High Density Programmable Constant Current Class 2 LED Driver with 0-10 V Dimming, and with Optional Auxiliary Output

■ 16 - PROGRAMMING

The PLH series can be programmed by inserting the audio jack of the cable shown in figure 9 into the driver and by plugging the USB other end of the cable into a computer. The driver should not be powered on during the programming process.

When ordering the PLH series, please order a programming cable (**PROG-JACK-USB**). For high-volume programming applications, an optional programming cradle (**PROG-PLH-CRADLE**) is also available.

Programming is done by using the ERP LED Driver Configuration Tool (also known as ERP GUI), downloadable through the ERP website (<https://www.erp-power.com/erp-light-engines/led-light-programming-software/>), which enables the user to adjust output current and dimming profile.

Please note that, for each model, the **default output current setting is listed on page 2 of this datasheet.**

Furthermore, when connecting the driver to a computer using the programming cable, you can access the driver's internal data log and read the following information: SKU, serial number, manufacturing lot code, hours of operation, firmware revision, and power cycles.

While programming drivers in a lot, the ERP GUI can interface with a label printer, which enables the user to add configuration labels to driver labels in order to highlight programmed output current. Listed below is the equipment needed to print labels.

Equipment	Part Number	Where to buy
Printer	TSC TC210	barcodefactory.com/tsc/printers/tc210/99-059a001-54lf
Ribbon	TSC Prem. Resin, 60mm x 110mm	barcodefactory.com/tsc/35-r060110-23cf
Labels	BAR-.81x.28-1-TT	barcodefactory.com/barcodefactory/labels/bar-.81x.28-1-tt

For more information, please refer to the ERP LED Driver Configuration Tool user's manual at: (<https://www.erp-power.com/erp-light-engines/led-light-programming-software/>).

IMPORTANT NOTE: During the first power-up, the PLH automatically executes an internal calibration and synchronization routine during which it interrogates the LED load. This routine ensures that when multiple PLH drivers are installed within a single luminaire, such as extended linear fixtures, or across adjacent luminaires, they all start up and shut down in a synchronized manner, thereby eliminating the “popcorning” effect that can occur during asynchronous driver start-up.

The calibration process typically completes within 5 to 10 seconds. This process also occurs anytime the LED load (Vf) changes or the output current is re-programmed.

Each time the LED load (Vf) is changed, or the output current is re-programmed, the power-up cycle will exhibit a brief delay accompanied by an audible tone. This behavior is intentional and fully expected. The PLH series incorporates embedded intelligence designed to eliminate the popcorning effect.

Once this calibration is complete, all subsequent power-up events proceed normally with no delay or audible indication, provided that the LED load and output current remain unchanged.

Programming Cradle
Part number: PROG-PLH-CRADLE

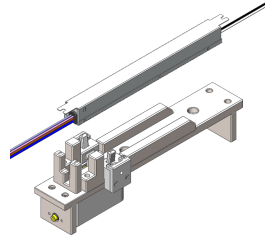

Programming Cable
Part number: PROG-JACK-USB



Figure 9

20 to 65 W High Density Programmable Constant Current Class 2 LED Driver with 0-10 V Dimming, and with Optional Auxiliary Output

17 - PREDICTED LIFETIME VERSUS CASE AND AMBIENT TEMPERATURE

Lifetime is defined by the measurement of the temperatures of all the electrolytic capacitors whose failure would affect light output under the nominal LED load and worst-case AC line voltage. The graphs in figures 10, 11, 12, and 13 are determined by the electrolytic capacitor with the shortest lifetime, among all electrolytic capacitors. It represents a worst-case scenario in which the LED driver is powered 24 hours/day, 7 days/week. The lifetime of an electrolytic capacitor is measured when any of the following changes in performance are observed:

- 1) Capacitance changes more than 20% of initial value
- 2) Dissipation Factor ($\tan \delta$): 150% or less of initial specified value
- 3) Equivalent Series Resistance (ESR): 150% or less of initial specified value
- 4) Leakage current: less of initial specified value

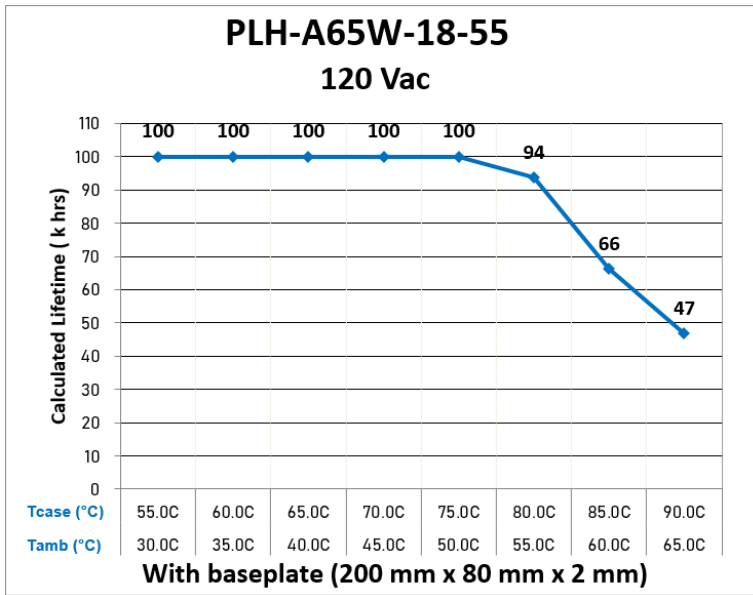

Figure 10

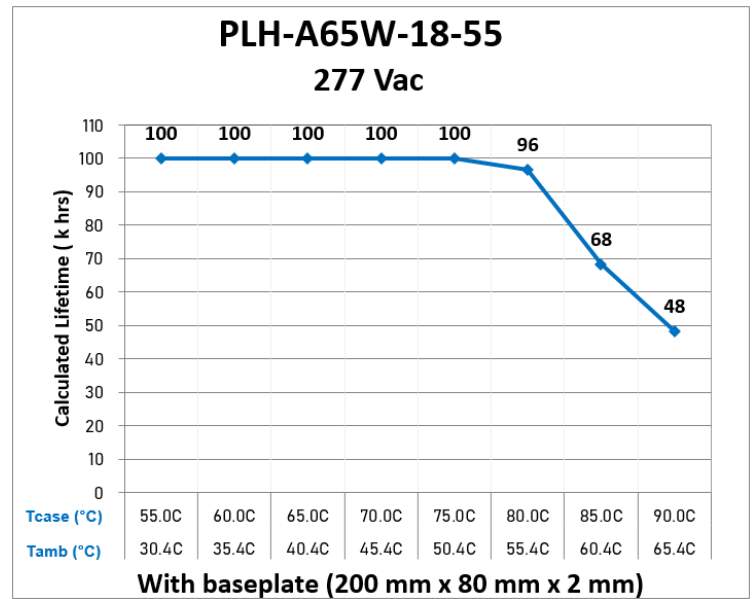

Figure 11

20 to 65 W High Density Programmable Constant Current Class 2 LED Driver with 0-10 V Dimming, and with Optional Auxiliary Output

17 - PREDICTED LIFETIME VERSUS CASE AND AMBIENT TEMPERATURE (CONTINUED)

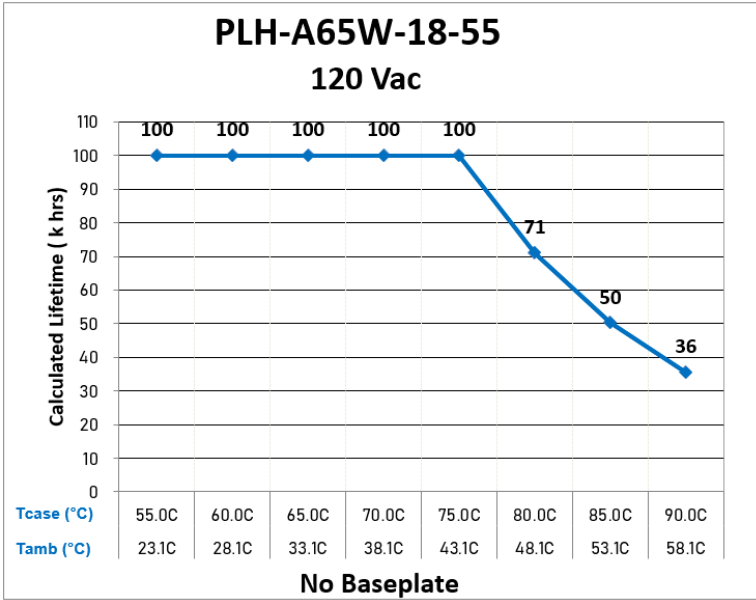

Figure 12

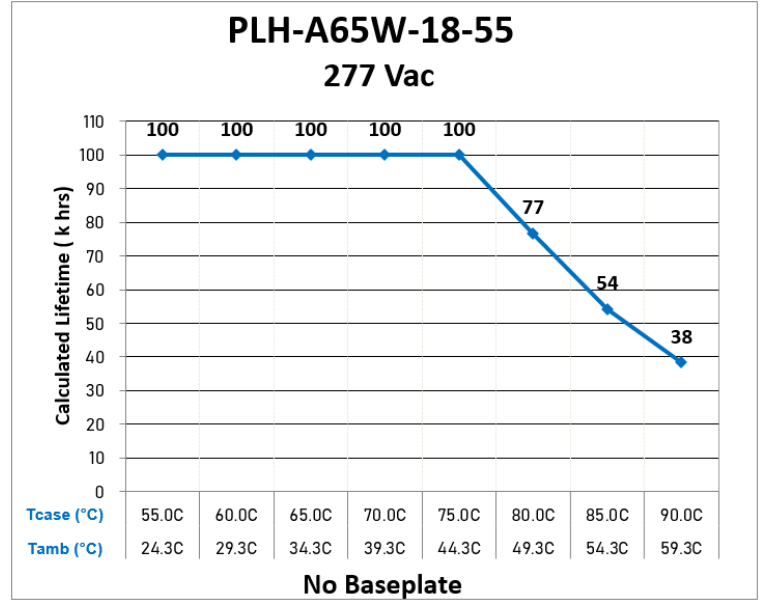

Figure 13

NOTES:

- The ambient temperature ($T_{ambient}$) and the temperature differential between $T_{ambient}$ and T_{case} (case temperature) shown in the graphs above are only applicable when both the LED driver and the luminaire are operating within the same ambient environment. If the LED driver is enclosed or insulated, the ambient room temperature no longer represents the actual operating conditions. In such cases, the ambient temperature should be defined as the air temperature immediately surrounding the LED driver, and thermal performance should be evaluated based solely on the case temperature (T_{case}).
- It should be noted the graph “Lifetime vs. Ambient Temperature” may have an error induced in the final application if the mounting has restricted convection flow around the case. For applications where this is evident, the actual case temperature measured at the Tc point in the application should be used for reliability calculations.
- Users must utilize proper thermal management techniques to ensure proper thermal conductivity between the driver and heat sink. The use of double-sided tape, Velcro, etc... to mount the driver voids the warranty.

20 to 65 W High Density Programmable Constant Current Class 2 LED Driver with 0-10 V Dimming, and with Optional Auxiliary Output

18 – EFFICIENCY VERSUS OUTPUT VOLTAGE (100% OF OUTPUT CURRENT)

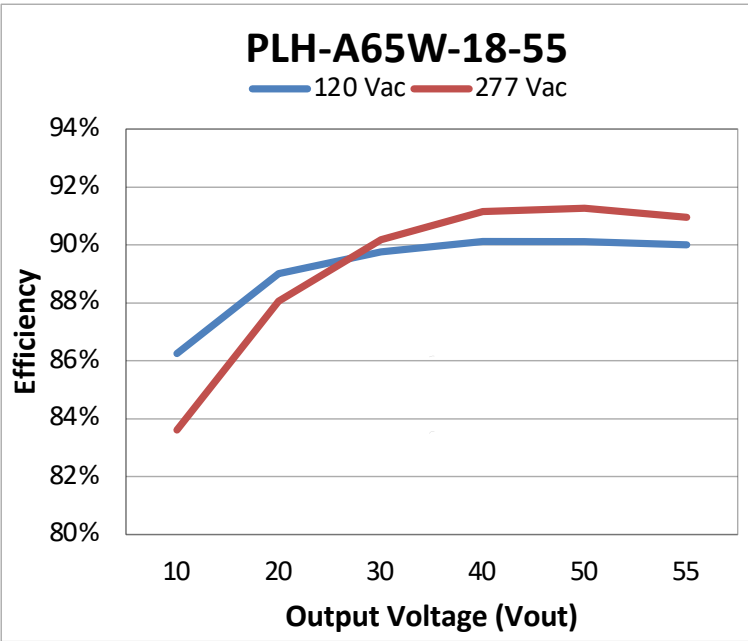

Figure 14

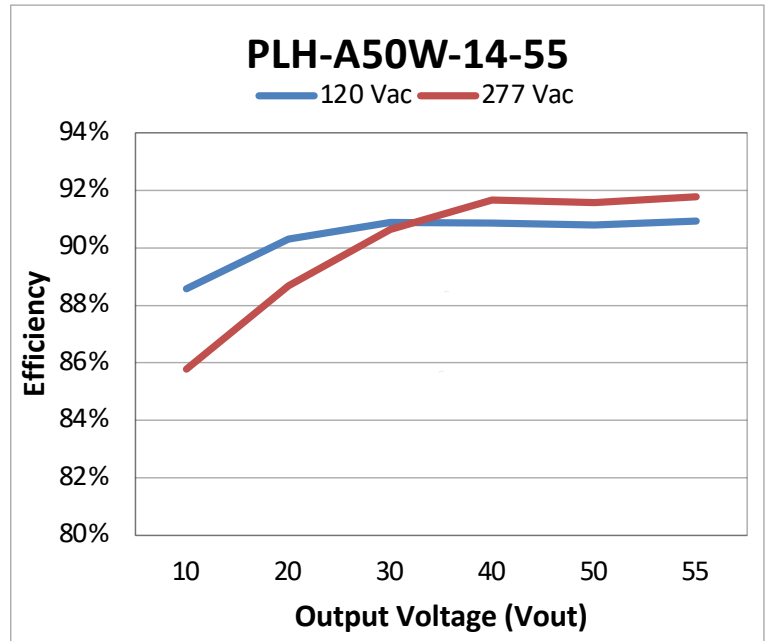

Figure 15

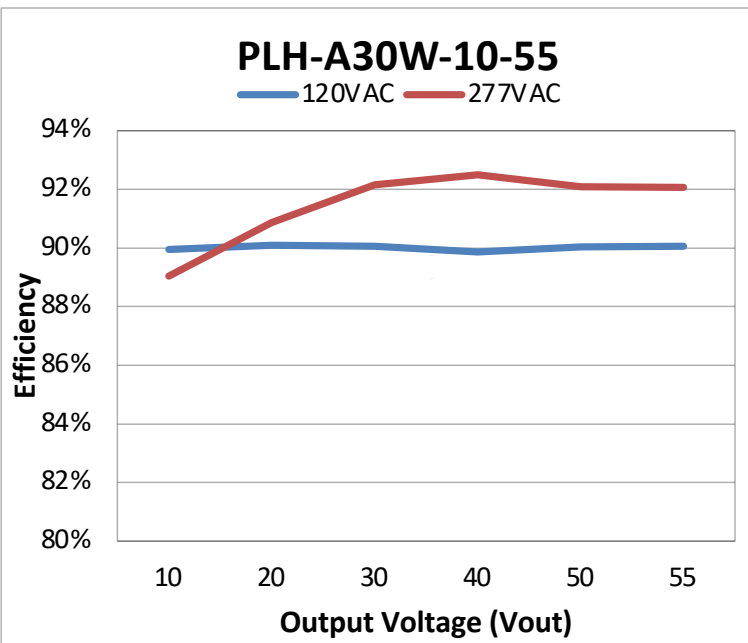

Figure 16

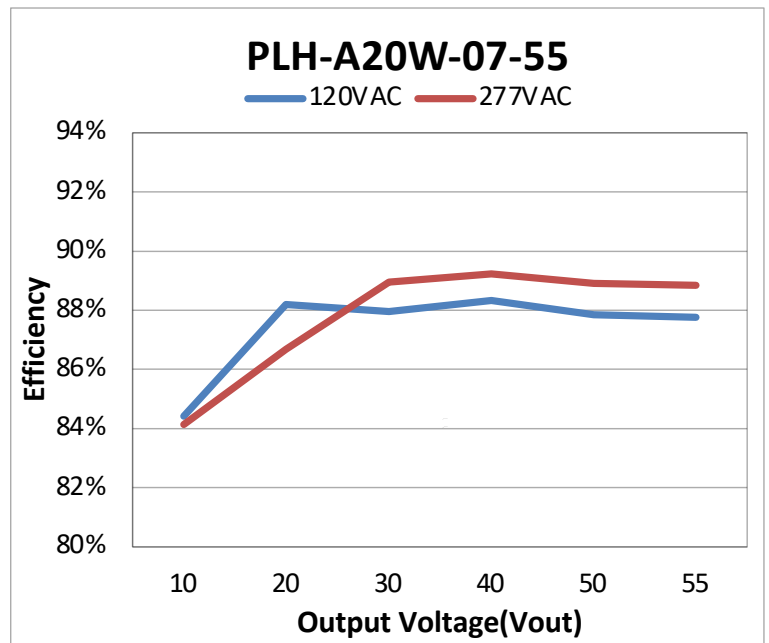

Figure 17

20 to 65 W High Density Programmable Constant Current Class 2 LED Driver with 0-10 V Dimming, and with Optional Auxiliary Output

19 – POWER FACTOR VERSUS OUTPUT VOLTAGE (100% OF OUTPUT CURRENT)

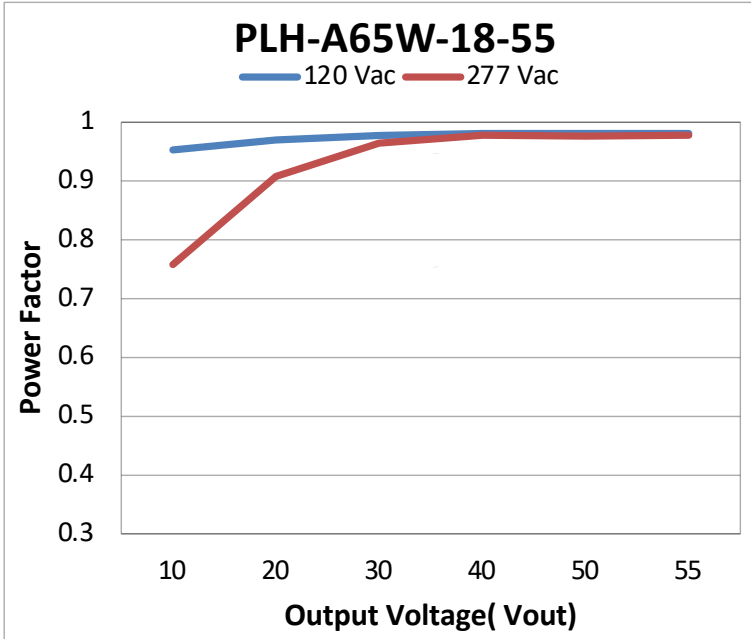

Figure 18

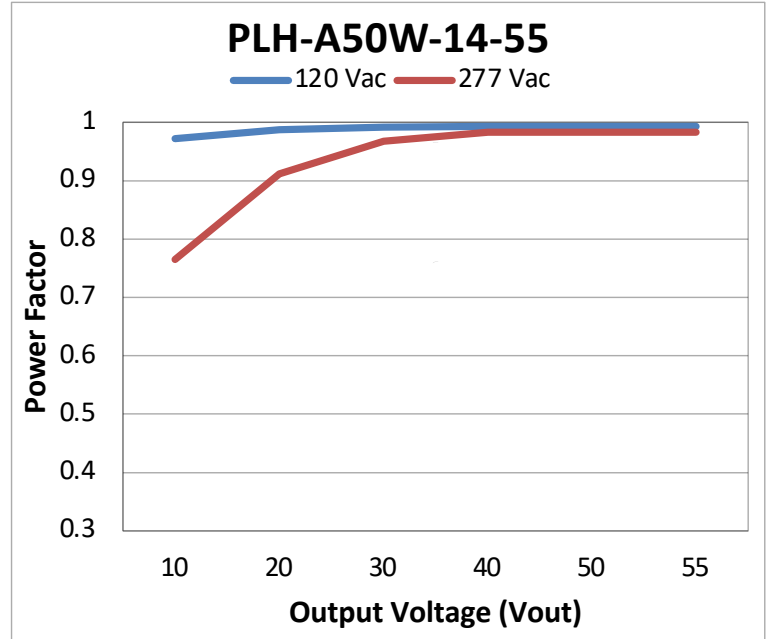

Figure 19

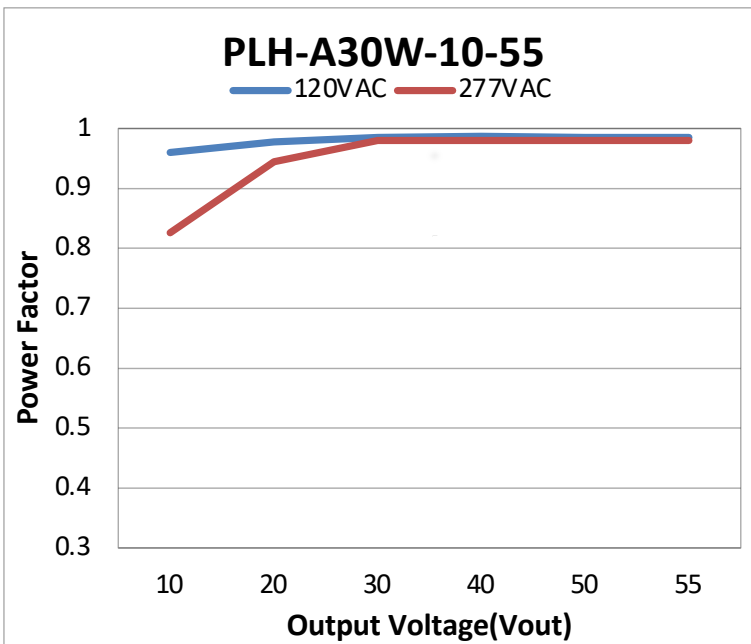

Figure 20

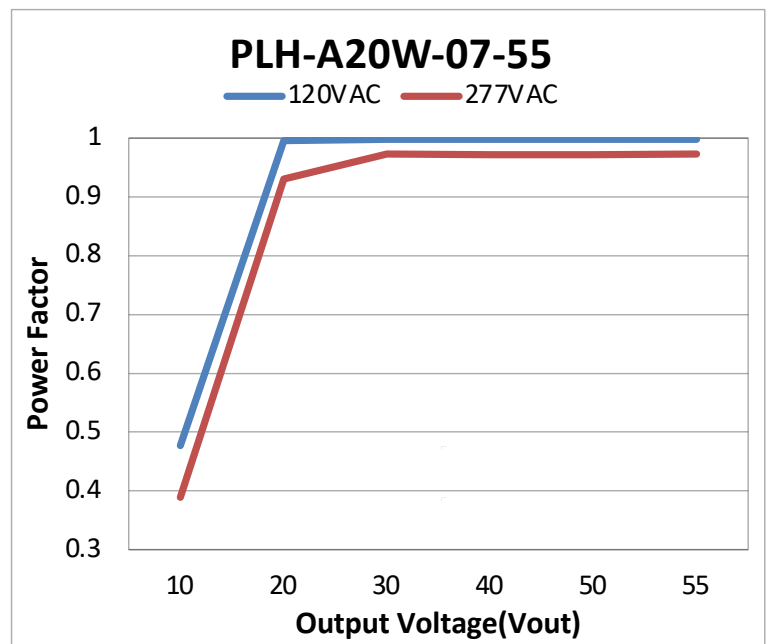

Figure 21

NOTE: For proper operation, please also refer to the OPERATING ENVELOPE in section 3, which defines the permissible ranges of output current and output voltage where THD and PF compliance is maintained.

20 to 65 W High Density Programmable Constant Current Class 2 LED Driver with 0-10 V Dimming, and with Optional Auxiliary Output

20 – THD VERSUS OUTPUT VOLTAGE (100% OF OUTPUT CURRENT)

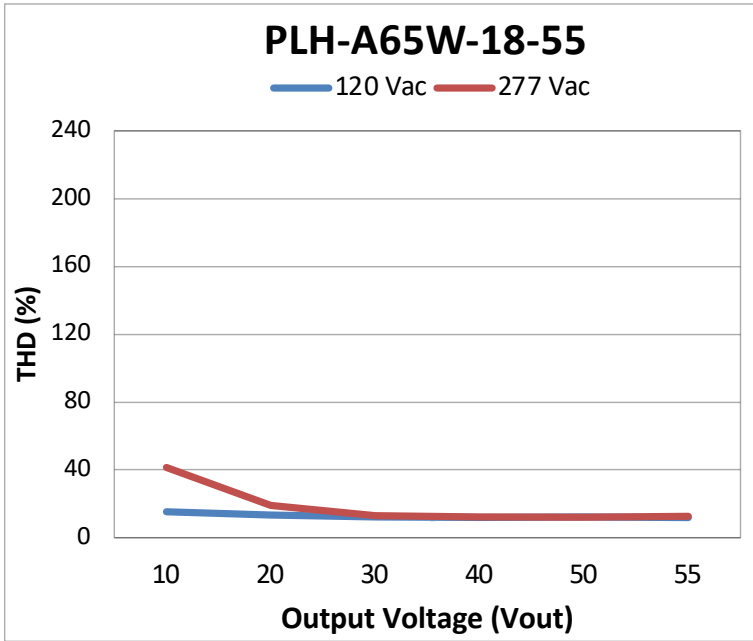

Figure 22

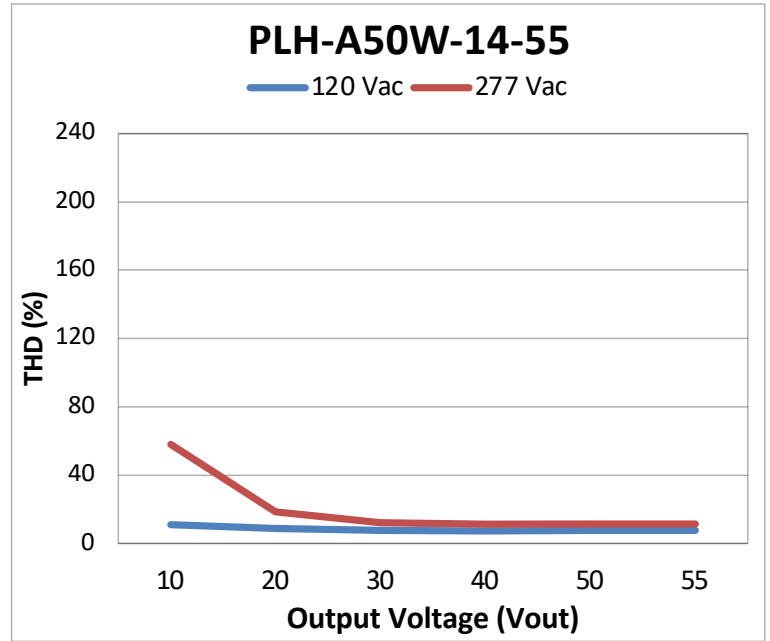

Figure 23

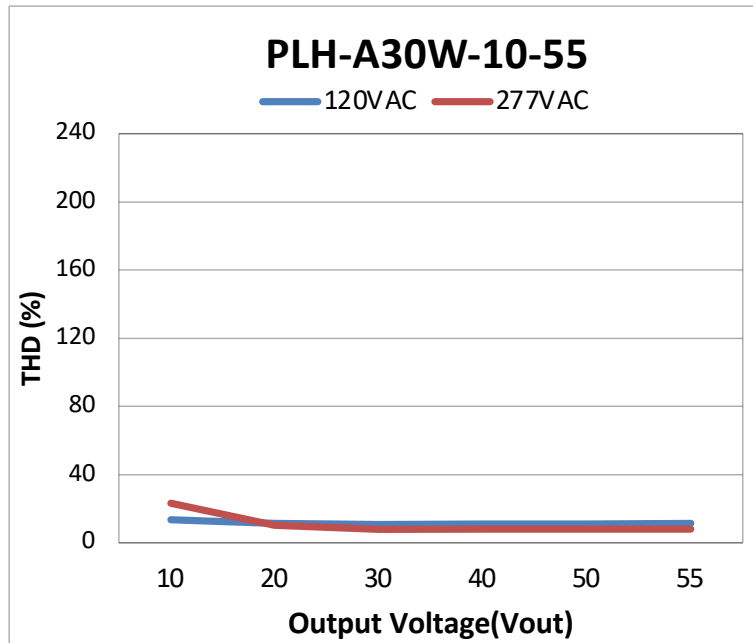

Figure 24

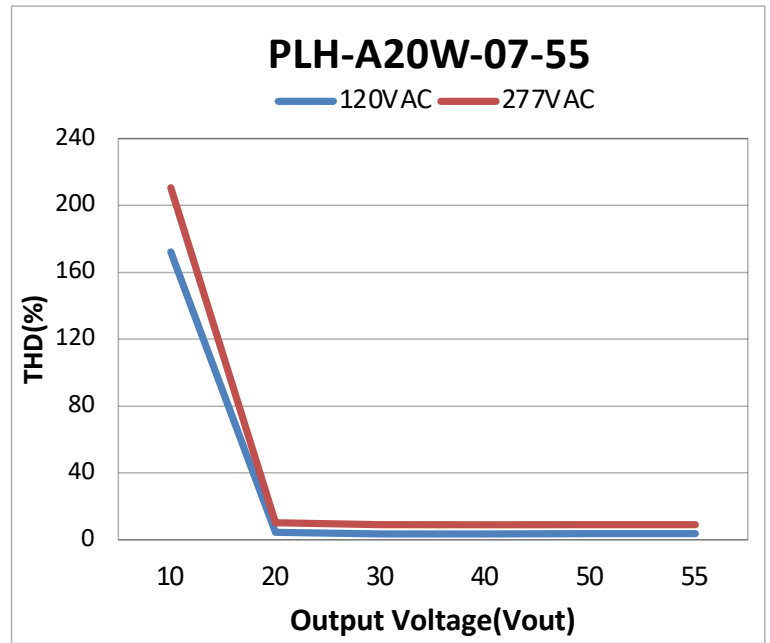

Figure 25

NOTE: For proper operation, please also refer to the OPERATING ENVELOPE in section 3, which defines the permissible ranges of output current and output voltage where THD and PF compliance is maintained.

20 to 65 W High Density Programmable Constant Current Class 2 LED Driver with 0-10 V Dimming, and with Optional Auxiliary Output

21 - MECHANICAL DETAILS (-SZ MODELS, NO AUXILIARY OUTPUT)

- **Packaging:** Aluminum case
- **I/O Connections:** 18 AWG on input and output leads, 22 AWG on 0-10V dimming and auxiliary output wires, 105°C, rated, stranded, stripped by approximately 9.5 mm, and tinned. All the wires, on both input and output, have a 300 V insulation rating.
- **Wire Length:**
 - INPUT**
 - AC Neutral (White): 152 mm (6 inches)
 - AC Phase (Black): 203 mm (8 inches)
 - OUTPUT**
 - LED Output (+ Red): 203 mm (8 inches)
 - LED Output (- Blue): 152 mm (6 inches)
 - DIMMING**
 - + Dim (Purple): 203 mm (8 inches)
 - - Dim (pink): 203 mm (8 inches)
- **Ingress Protection:** IP20 rated
- **Mounting Instructions:** The PLH driver case must be secured on a flat surface through the two mounting tabs, shown here below in the case outline drawings. The use of double-sided tape voids the warranty. The screw mounting holes have a diameter of 3.8 mm, compatible with screw size #6 (UNC/UNF), M3 or M3.5 (ISO).
THE CASE MUST BE GROUNDED.

22 - OUTLINE DRAWINGS (-SZ MODELS, NO AUXILIARY OUTPUT)

Dimensions: L 197.4 * W 19.65 * H 19.25 mm (L 7.77 * W 0.77 * H 0.76 in.)

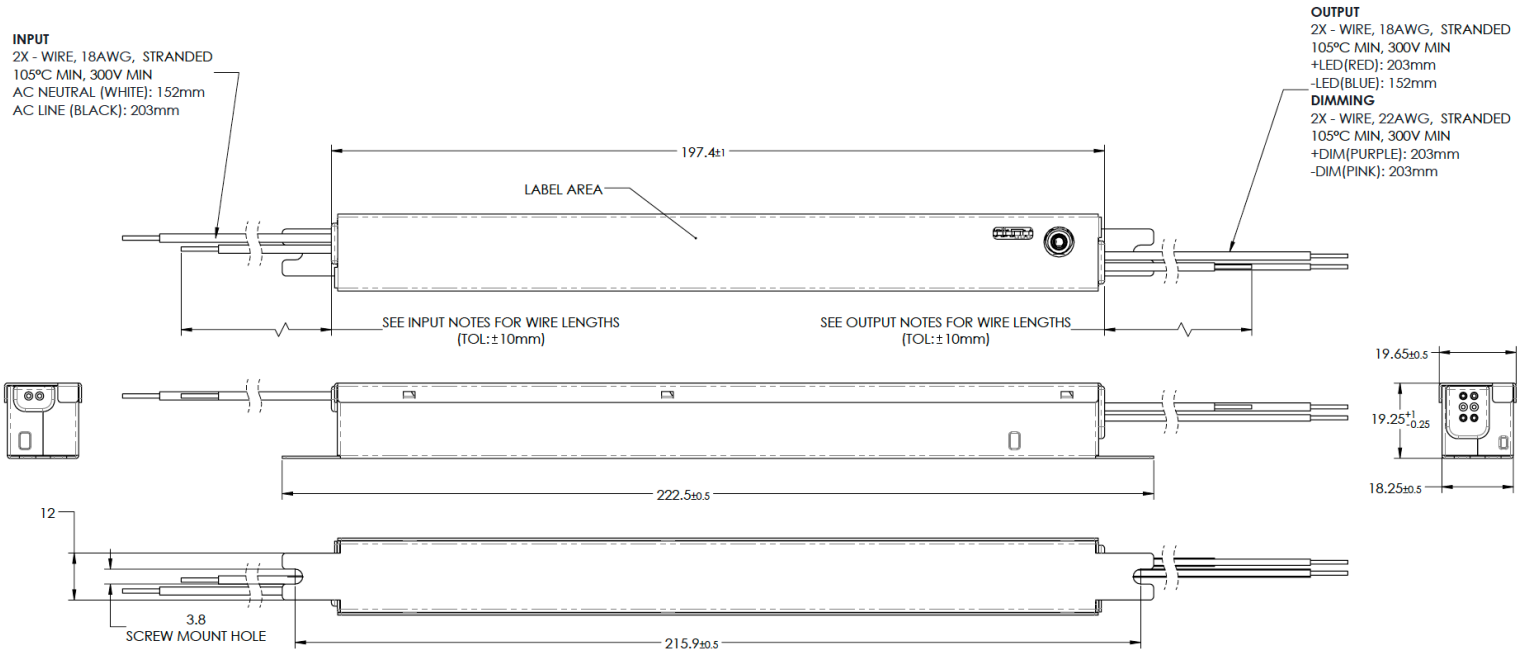

Figure 26

20 to 65 W High Density Programmable Constant Current Class 2 LED Driver with 0-10 V Dimming, and with Optional Auxiliary Output

23 - MECHANICAL DETAILS (-SXZ MODELS, WITH AUXILIARY OUTPUT)

- **Packaging:** Aluminum case
- **I/O Connections:** 18 AWG on input and output leads, 22 AWG on 0-10V dimming and auxiliary output wires, 105°C, rated, stranded, stripped by approximately 9.5 mm, and tinned. All the wires, on both input and output, have a 300 V insulation rating.
- **Wire Length:**
 - INPUT**
 - AC Neutral (White): 152 mm (6 inches)
 - AC Phase (Black): 203 mm (8 inches)
 - OUTPUT**
 - LED Output (+ Red): 203 mm (8 inches)
 - LED Output (- Blue): 152 mm (6 inches)
 - DIMMING**
 - + Dim (Purple): 203 mm (8 inches)
 - - Dim (pink): 203 mm (8 inches)
 - AUXILIARY OUTPUT**
 - + Aux (Yellow): 203 mm (8 inches)
 - - Aux (Grey): 203 mm (8 inches)
- **Ingress Protection:** IP20 rated
- **Mounting Instructions:** The PLH driver case must be secured on a flat surface through the two mounting tabs, shown here below in the case outline drawings. The use of double-sided tape voids the warranty. The screw mounting holes have a diameter of 3.8 mm, compatible with screw size #6 (UNC/UNF), M3 or M3.5 (ISO). **THE CASE MUST BE GROUNDED.**

24 - OUTLINE DRAWINGS (-SXZ MODELS, WITH AUXILIARY OUTPUT)

Dimensions: L 197.4 * W 19.65 * H 19.25 mm (L 7.77 * W 0.77 * H 0.76 in.)

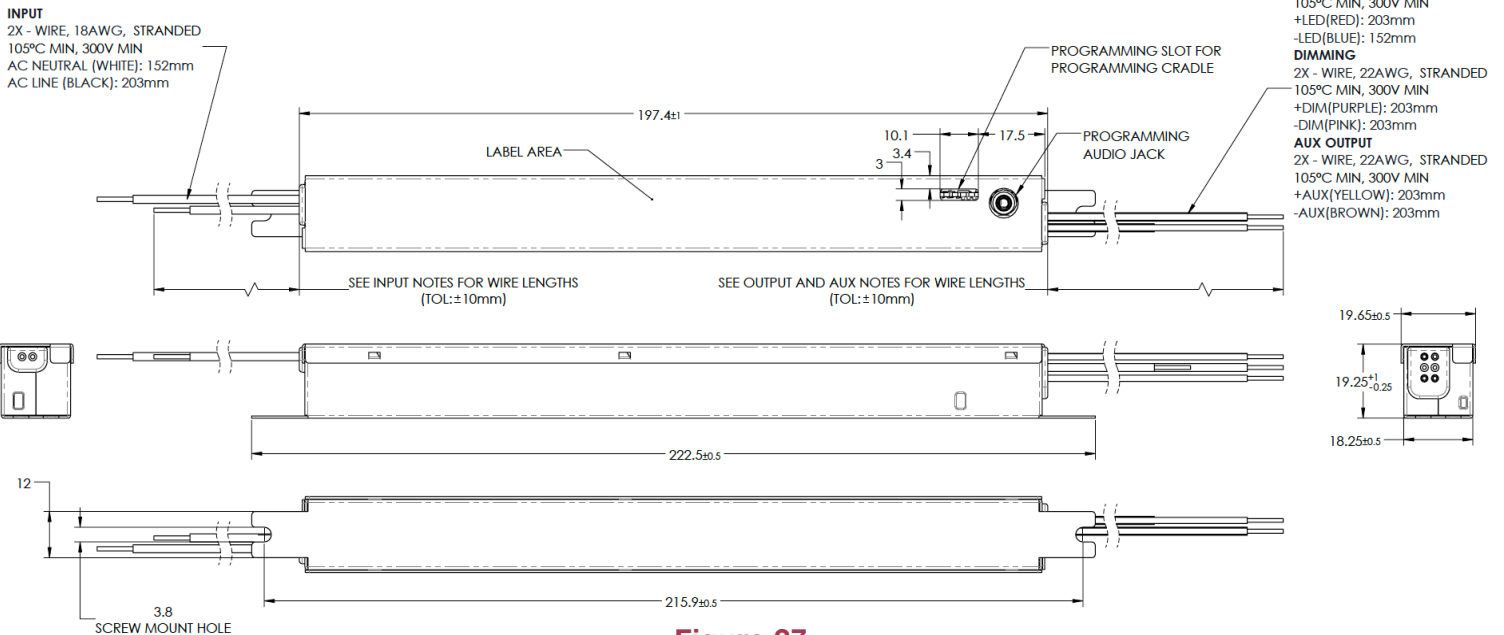

Figure 27



POWER + LIGHT™

PLH Series

PLH-A20	20 W
PLH-A30	30 W
PLH-A50	50 W
PLH-A65	65 W

20 to 65 W High Density Programmable Constant Current Class 2 LED Driver with 0-10 V Dimming, and with Optional Auxiliary Output

25 - LABELING

The PLH-A65W-18-55-SXZ is used in figure 28 as an example to illustrate a typical label.

<p>PLH-A65W-18-55-SXZ DC Dimmable Constant Current LED Driver Max Case Temperature to = 90°C Suitable for Operation with 0-10V Dimmer Suitable for Dry or Damp Locations</p>	<p>AC INPUT: 120-277 V ~ 0.70A 50/60 Hz PF ≥ 0.9, THD ≤ 20% L: BLACK N: WHITE</p>	<p>Designed in the USA Manufactured in China</p>	<p>For Connections Use Wire Rated for at Least 90°C (194°F) Pour Les Connexions, Utilisez Des Fils Conducteurs Spécifiés Pour 90°C Au Minimum Use only within an Enclosure / Doit Être Installé Dans Une Encoite</p>	<p>DC OUTPUT: Programmable Current 0.6-1.8 A --- Maximum Power 65 W Voltage Range 10-55 Vdc No Load Voltage < 60 Vdc RED: + LEDS BLUE: - LEDS (0-10V Dimming) PURPLE: + DIM PINK: - DIM</p>
	<p>CASE MUST BE GROUNDED</p>	<p>CONFIGURATION AFTER PROGRAMMING (Default Current Setting: 1.2 A)</p>	<p>FC Class 2 Class P Use ERP Supplied Cables Only for Programming</p>	<p>UL US LISTED E343741</p>

Figure 28

The PLH-A65W-18-55-SZ is used in figure 29 as an example to illustrate a typical label.

<p>PLH-A65W-18-55-SZ DC Dimmable Constant Current LED Driver Max Case Temperature to = 90°C Suitable for Operation with 0-10V Dimmer Suitable for Dry or Damp Locations</p>	<p>AC INPUT: 120-277 V ~ 0.70A 50/60 Hz PF ≥ 0.9, THD ≤ 20% L: BLACK N: WHITE</p>	<p>Designed in the USA Manufactured in China</p>	<p>For Connections Use Wire Rated for at Least 90°C (194°F) Pour Les Connexions, Utilisez Des Fils Conducteurs Spécifiés Pour 90°C Au Minimum Use only within an Enclosure / Doit Être Installé Dans Une Encoite</p>	<p>DC OUTPUT: Programmable Current 0.6-1.8 A --- Maximum Power 65 W Voltage Range 10-55 Vdc No Load Voltage < 60 Vdc RED: + LEDS BLUE: - LEDS (0-10V Dimming) PURPLE: + DIM PINK: - DIM WARNING: - LEDS IS NOT GROUND</p>
	<p>CASE MUST BE GROUNDED</p>	<p>CONFIGURATION AFTER PROGRAMMING (Default Current Setting: 1.2 A)</p>	<p>FC Class 2 Class P Use ERP Supplied Cables Only for Programming</p>	<p>UL US LISTED E343741</p>

Figure 29

USA Headquarters
Tel: +1-805-517-1300
Fax: +1-805-517-1411
2625 Townsgate Road, Suite 106
Westlake Village, CA 91361, USA

CHINA Operations
Tel: +86-756-6266298
Fax: +86-756-6266299
No. 8 Pingdong Road 2
Zhuhai, Guangdong, China 519060

ERP Power, LLC (ERP) reserves the right to make changes without further notice to any products herein. ERP makes no warranty, representation or guarantee regarding the suitability of its products for any particular purpose, nor does ERP assume any liability arising out of the application or use of any product or circuit, and specifically disclaims any and all liability, including without limitation special, consequential or incidental damages. "Typical" parameters which may be provided in ERP data sheets and/or specifications can and do vary in different applications and actual performance may vary over time. All operating parameters, including "Typicals" must be validated for each customer application by customer's technical experts. ERP does not convey any license under its patent rights nor the rights of others. ERP products are not designed, intended, or authorized for use as components in systems intended for surgical implant into the body, or other applications intended to support or sustain life, or for any other application in which the failure of the ERP product could create a situation where personal injury or death may occur. Should Buyer purchase or use ERP products for any such unintended or unauthorized application, Buyer shall indemnify and hold ERP and its officers, employees, subsidiaries, affiliates, and distributors harmless against all claims, costs, damages, and expenses, and reasonable attorney fees arising out of, directly or indirectly, any claim of personal injury or death associated with such unintended or unauthorized use, even if such claim alleges that ERP was negligent regarding the design or manufacture of the part. ERP is an Equal Opportunity/Affirmative Action Employer. This literature is subject to all applicable copyright laws and is not for resale in any manner.



POWER + LIGHT™

PLH Series

PLH-A20 20 W
PLH-A30 30 W
PLH-A50 50 W
PLH-A65 65 W

20 to 65 W High Density Programmable Constant Current Class 2 LED Driver with 0-10 V Dimming, and with Optional Auxiliary Output

Revision History

Date	Comments
04MAY2026	• Final release